

Deutsches Institut für Bautechnik

Anstalt des öffentlichen Rechts

Kolonnenstr. 30 L
10829 Berlin
Germany

Tel.: +49(0)30 787 30 0
Fax: +49(0)30 787 30 320
E-mail: dibt@dibt.de
Internet: www.dibt.de

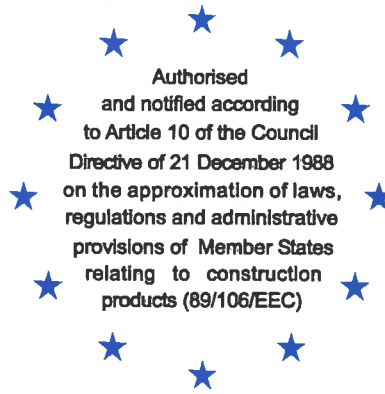

DIBt

Mitglied der EOTA
Member of EOTA

European Technical Approval ETA-04/0003

English translation prepared by DIBt - Original version in German language

Handelsbezeichnung
Trade name

fischer Schwerlastanker TA M, TA M S, TA M T
fischer Heavy-duty anchor TA M, TA M S, TA M T

Zulassungsinhaber
Holder of approval

fischerwerke GmbH & Co. KG
Weinhalde 14-18
72178 Waldachtal
DEUTSCHLAND

**Zulassungsgegenstand
und Verwendungszweck**

*Generic type and use
of construction product*

Kraftkontrolliert spreizender Dübel aus galvanisch verzinktem
Stahl in den Größen M 6, M 8, M 10 und M 12 zur
Verankerung im ungerissenen Beton
*Torque controlled expansion anchor made of galvanised steel of sizes M 6,
M 8, M 10 and M 12 for use in non-cracked concrete*

Geltungsdauer: vom
Validity: from
bis
to

9 March 2009
9 March 2014

Herstellwerk
Manufacturing plant

fischerwerke

Diese Zulassung umfasst
This Approval contains

15 Seiten einschließlich 8 Anhänge
15 pages including 8 annexes

Diese Zulassung ersetzt
This Approval replaces

ETA-04/0003 mit Geltungsdauer vom 13.01.2004 bis 13.01.2009
ETA-04/0003 with validity from 13.01.2004 to 13.01.2009



Europäische Organisation für Technische Zulassungen
European Organisation for Technical Approvals

I LEGAL BASES AND GENERAL CONDITIONS

- 1 This European technical approval is issued by Deutsches Institut für Bautechnik in accordance with:
 - Council Directive 89/106/EEC of 21 December 1988 on the approximation of laws, regulations and administrative provisions of Member States relating to construction products¹, modified by Council Directive 93/68/EEC² and Regulation (EC) N° 1882/2003 of the European Parliament and of the Council³;
 - Gesetz über das In-Verkehr-Bringen von und den freien Warenverkehr mit Bauprodukten zur Umsetzung der Richtlinie 89/106/EWG des Rates vom 21. Dezember 1988 zur Angleichung der Rechts- und Verwaltungsvorschriften der Mitgliedstaaten über Bauprodukte und anderer Rechtsakte der Europäischen Gemeinschaften (Bauproduktengesetz - BauPG) vom 28. April 1998⁴, as amended by law of 31 October 2006⁵;
 - Common Procedural Rules for Requesting, Preparing and the Granting of European technical approvals set out in the Annex to Commission Decision 94/23/EC⁶;
 - Guideline for European technical approval of "Metal anchors for use in concrete - Part 2: Torque controlled expansion anchors ", ETAG 001-02.
- 2 Deutsches Institut für Bautechnik is authorized to check whether the provisions of this European technical approval are met. Checking may take place in the manufacturing plant. Nevertheless, the responsibility for the conformity of the products to the European technical approval and for their fitness for the intended use remains with the holder of the European technical approval.
- 3 This European technical approval is not to be transferred to manufacturers or agents of manufacturers other than those indicated on page 1, or manufacturing plants other than those indicated on page 1 of this European technical approval.
- 4 This European technical approval may be withdrawn by Deutsches Institut für Bautechnik, in particular pursuant to information by the Commission according to Article 5(1) of Council Directive 89/106/EEC.
- 5 Reproduction of this European technical approval including transmission by electronic means shall be in full. However, partial reproduction can be made with the written consent of Deutsches Institut für Bautechnik. In this case partial reproduction has to be designated as such. Texts and drawings of advertising brochures shall not contradict or misuse the European technical approval.
- 6 The European technical approval is issued by the approval body in its official language. This version corresponds fully to the version circulated within EOTA. Translations into other languages have to be designated as such.

1 Official Journal of the European Communities L 40, 11 February 1989, p. 12

2 Official Journal of the European Communities L 220, 30 August 1993, p. 1

3 Official Journal of the European Union L 284, 31 October 2003, p. 25

4 *Bundesgesetzblatt Teil I 1998*, p. 812

5 *Bundesgesetzblatt Teil I 2006*, p.2407, 2416

6 Official Journal of the European Communities L 17, 20 January 1994, p. 34

II SPECIFIC CONDITIONS OF THE EUROPEAN TECHNICAL APPROVAL

1 Definition of product and intended use

1.1 Definition of product

The Fischer Heavy-duty anchor TA M, TA M S and TA M T in the range of M 6, M 8, M 10 and M 12 is an anchor made of galvanised steel which is placed into a drilled hole and anchored by torque-controlled expansion with the hexagon head bolt.

The hexagon head bolt of property class 8.8 acc. to EN 898-1:1999 and the washer for anchor type TA M shall be purchased by the user.

For the different types of the installed anchors see Figure given in Annex 1.

1.2 Intended use

The anchor is intended to be used for anchorages for which requirements for mechanical resistance and stability and safety in use in the sense of the Essential Requirements 1 and 4 of Council Directive 89/106 EEC shall be fulfilled and failure of anchorages made with these products would cause risk to human life and/or lead to considerable economic consequences.

The anchor is to be used only for anchorages subject to static or quasi-static loading in reinforced or unreinforced normal weight concrete of strength classes C20/25 at minimum and C50/60 at most according to EN 206:2000-12.

It may be anchored in non-cracked concrete only.

The anchor may only be used in structures subject to dry internal conditions.

The provisions made in this European technical approval are based on an assumed working life of the anchor of 50 years. The indications given on the working life cannot be interpreted as a guarantee given by the producer, but are to be regarded only as a means for choosing the right products in relation to the expected economically reasonable working life of the works.

2 Characteristics of the product and methods of verification

2.1 Characteristics of the product

The anchor corresponds to the drawings and provisions given in Annex 3. The characteristic material values, dimensions and tolerances of the anchor not given in Annex 3 shall correspond to the respective values laid down in the technical documentation⁷ of this European technical approval.

The hexagon head bolt and the washer for anchor type TA M shall correspond to the specifications given in Annex 5, Table 4 and 5.

The characteristic values for the design of anchorages are given in Annexes 4 to 7.

Each anchor is marked with the identifying mark of the producer included the commercial name, the drill hole diameter and the thread size according to Annex 2.

The anchor shall only be packaged and supplied as a complete unit.

2.2 Methods of verification

The assessment of fitness of the anchor for the intended use in relation to the requirements for mechanical resistance and stability and safety in use in the sense of the Essential Requirements 1 and 4 has been made in accordance with the "Guideline for European

⁷ The technical documentation of this European technical approval is deposited at the Deutsches Institut für Bautechnik and, as far as relevant for the tasks of the approved bodies involved in the attestation of conformity procedure, is handed over to the approved bodies.

technical approval of Metal Anchors for Use in Concrete", Part 1 "Anchors in general" and Part 2 "Torque-controlled expansion anchors", on the basis of Option 7.

In addition to the specific clauses relating to dangerous substances contained in this European technical approval, there may be other requirements applicable to the products falling within its scope (e. g. transposed European legislation and national laws, regulations and administrative provisions). In order to meet the provisions of the Construction Products Directive, these requirements need also to be complied with, when and where they apply.

3 Evaluation and attestation of conformity and CE marking

3.1 System of attestation of conformity

According to the decision 96/582/EG of the European Commission⁸ the system 2(i) (referred to as system 1) of attestation of conformity applies.

This system of attestation of conformity is defined as follows:

System 1: Certification of the conformity of the product by an approved certification body on the basis of:

- (a) Tasks for the manufacturer:
 - (1) factory production control;
 - (2) further testing of samples taken at the factory by the manufacturer in accordance with a prescribed test plan;
- (b) Tasks for the approved body:
 - (3) initial type-testing of the product;
 - (4) initial inspection of factory and of factory production control;
 - (5) continuous surveillance, assessment and approval of factory production control.

3.2 Responsibilities

3.2.1 Tasks of the manufacturer

3.2.1.1 Factory production control

The manufacturer shall exercise permanent internal control of production. All the elements, requirements and provisions adopted by the manufacturer shall be documented in a systematic manner in the form of written policies and procedures, including records of results performed. This production control system shall insure that the product is in conformity with this European technical approval.

The manufacturer may only use initial/ raw/ constituent materials stated in the technical documentation of this European technical approval.

The factory production control shall be in accordance with the control plan of January 2009 which is part of the technical documentation of this European technical approval. The control plan is laid down in the context of the factory production control system operated by the manufacturer and deposited at Deutsches Institut für Bautechnik⁹.

The results of factory production control shall be recorded and evaluated in accordance with the provisions of the control plan.

3.2.1.2 Other tasks of manufacturer

The manufacturer shall, on the basis of a contract, involve a body which is approved for the tasks referred to in section 3.1 in the field of anchors in order to undertake the actions laid down in section 3.2.2. For this purpose, the control plan referred to in sections 3.2.1.1 and 3.2.2 shall be handed over by the manufacturer to the approved body involved.

⁸ Official Journal of the European Communities L 254 of 08.10.1996.

⁹ The control plan is a confidential part of the documentation of the European technical approval, but not published together with the European technical approval and only handed over to the approved body involved in the procedure of attestation of conformity.
See section 3.2.2.

The manufacturer shall make a declaration of conformity, stating that the construction product is in conformity with the provisions of this European technical approval.

3.2.2 Tasks of approved bodies

The approved body shall perform the

- initial type-testing of the product ,
 - initial inspection of factory and of factory production control,
 - continuous surveillance, assessment and approval of factory production control,
- in accordance with the provisions laid down in the control plan.

The approved body shall retain the essential points of its actions referred to above and state the results obtained and conclusions drawn in a written report.

The approved certification body involved by the manufacturer shall issue an EC certificate of conformity of the product stating the conformity with the provisions of this European technical approval.

In cases where the provisions of the European technical approval and its control plan are no longer fulfilled the certification body shall withdraw the certificate of conformity and inform Deutsches Institut für Bautechnik without delay.

3.3 CE marking

The CE marking shall be affixed on each packaging of the anchor. The letters "CE" shall be followed by the identification number of the approved certification body, where relevant, and be accompanied by the following additional information:

- the name and address of the producer (legal entity responsible for the manufacturer),
- the last two digits of the year in which the CE marking was affixed,
- the number of the EC certificate of conformity for the product,
- the number of the European technical approval,
- the number of the guideline for European technical approval,
- use category (ETAG 001-1 Option 7),
- size.

4 Assumptions under which the fitness of the product for the intended use was favourably assessed

4.1 Manufacturing

The European technical approval is issued for the product on the basis of agreed data/information, deposited with Deutsches Institut für Bautechnik, which identifies the product that has been assessed and judged. Changes to the product or production process, which could result in this deposited data/information being incorrect, should be notified to Deutsches Institut für Bautechnik before the changes are introduced. Deutsches Institut für Bautechnik will decide whether or not such changes affect the approval and consequently the validity of the CE marking on the basis of the approval and if so whether further assessment or alterations to the approval shall be necessary.

4.2 Installation

4.2.1 Design of anchorages

The fitness of the anchor for the intended use is given under the following conditions:

The anchorages are designed in accordance with the "Guideline for European technical approval of Metal Anchors for Use in Concrete", Annex C, Method A under the responsibility of an engineer experienced in anchorages and concrete work.

Verifiable calculation notes and drawings are taking account of the loads to be anchored.

The position of the anchor is indicated on the design drawings (e. g. position of the anchor relative to reinforcement or to supports).

4.2.2 Installation of anchors

The fitness for use of the anchor can only be assumed if the anchor is installed as follows:

- Anchor installation carried out by appropriately qualified personnel and under the supervision of the person responsible for technical matters of the site,
- Use of the anchor only as supplied by the manufacturer without exchanging the components of an anchor,
- Anchor installation in accordance with the manufacturer's specifications and drawings and using the appropriate tools,
- Checks before placing the anchor to ensure that the strength class of the concrete in which the anchor is to be placed is in the range given and is not lower than that of the concrete to which the characteristic loads apply,
- Check of concrete being well compacted, e. g. without significant voids,
- Edge distances and spacings not less than the specified values without minus tolerances,
- Positioning of the drill holes without damaging the reinforcement,
- In case of aborted hole: new drilling at a minimum distance away of twice the depth of the aborted hole or smaller distance if the aborted drill hole is filled with high strength mortar and if under shear or oblique tension load it is not in the direction of load application,
- Cleaning of the hole of drilling dust,
- Anchor installation such that the effective anchorage depth is complied with. This compliance is ensured when the embedment mark of the anchor does no more exceed the concrete surface,
- The hexagon head bolt and the washer for anchor type TA M correspond to the specifications given in Annex 5.
- Application of the torque moment given in Annex 4 using a calibrated torque wrench.

4.2.3 Responsibility of the manufacturer

The manufacturer is responsible to ensure that the information on the specific conditions according to 1 and 2 including Annexes referred to and 4.2.1 and 4.2.2 is given to those who are concerned. This information may be made by reproduction of the respective parts of the European technical approval. In addition all installation data shall be shown clearly on the package and/or on an enclosed instruction sheet, preferably using illustration(s).

The minimum data required are:

- Diameter of drill bit,
- Thread diameter,
- Maximum thickness of the fixture,
- Minimum effective anchorage depth,
- Minimum hole depth,
- Torque moment,
- Information on the installation procedure, including cleaning of the hole, preferably by means of an illustration,
- Reference to any special installation equipment needed,
- Identification of the manufacturing batch.

All data shall be presented in a clear and explicit form.

Dipl.-Ing. E. Jasch
President of Deutsches Institut für Bautechnik
Berlin, 9 March 2009

beglaubigt:
Lange

Pre-positioned installation:

TA M

The hexagon head bolt and the washer according to table 4 and 5 must be purchased by the user

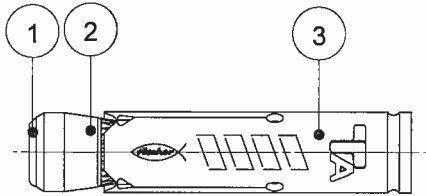

TA M S

The hexagon head bolt is provided by the manufacturer (fischer) together with the anchor

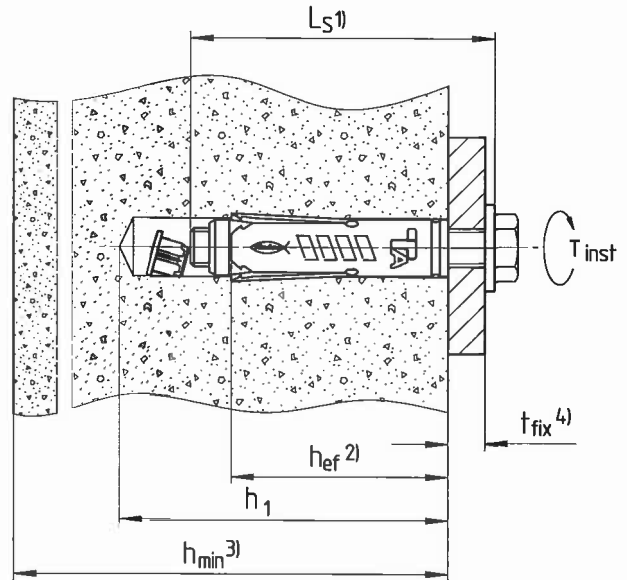
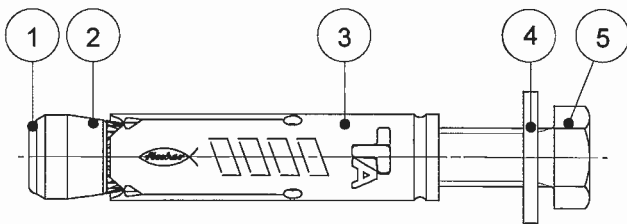

In-place installation:

TA M T

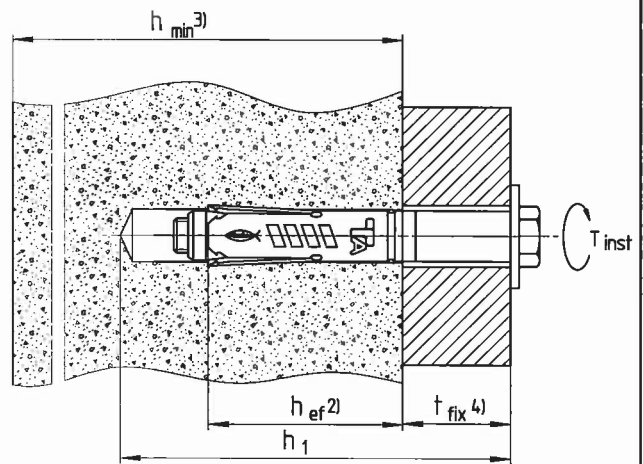
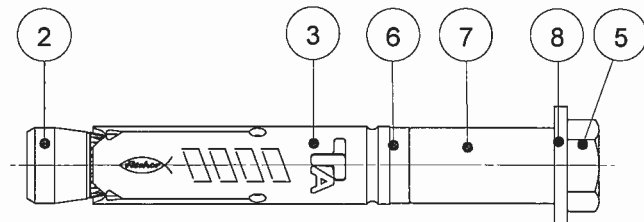

- ① Plastic cap (optional)
- ② Cone-nut
- ③ Expansion sleeve
- ④ Washer (TA M / TA M S)
- ⑤ Hexagon head bolt
- ⑥ Distance ring
- ⑦ Spacing sleeve
- ⑧ Washer (TA M T)

- 1) Length of hexagon head bolt L_s
- 2) Effective anchorage depth h_{ef}
- 3) Minimum thickness of concrete member h_{min}
- 4) Thickness of fixture t_{fix}

TA M / TA M S

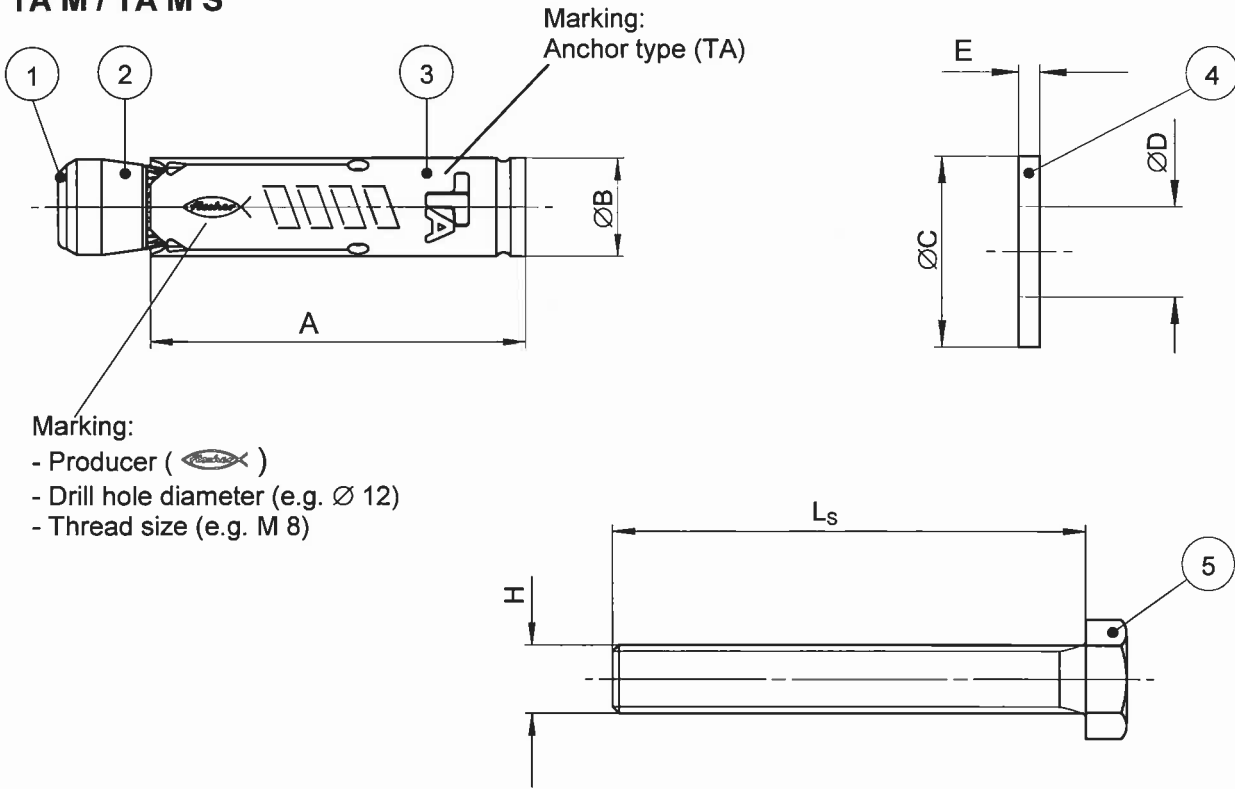

TA M T

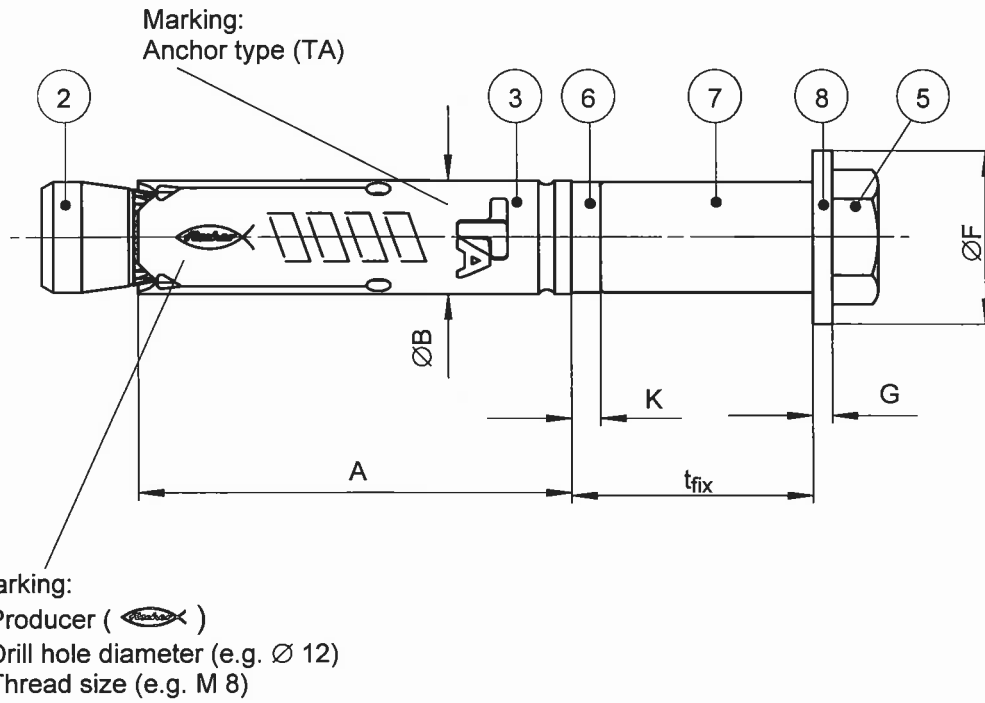

Doc: ETA-TAM-E

fischer Heavy-duty anchor TA M / TA M S / TA M T

Anchor components

Annex 2
of European
technical approval
ETA-04/0003

Table 1: Anchor dimensions [mm]

Part	Designation	Type of anchor	Dimension	M6	M8	M10	M12
3	Expansion sleeve	TA M / TA M S / TA M T	A =	40	45	55	70
			$\varnothing B =$	9,6	11,8	14,5	17,5
4	Washer ¹⁾	TA M S	$\varnothing C \geq$	11,0	15,0	19,0	23,0
			E \geq	1,4	1,4	1,8	2,3
8	Washer	TA M T	$\varnothing F \geq$	17,0	21,0	25,0	30,0
			G \geq	1,4	1,8	2,3	2,7
5	Hexagon head bolt ²⁾	TA M S / TA M T	$L_s \geq$	$t_{fix}+50$	$t_{fix}+55$	$t_{fix}+70$	$t_{fix}+85$
			H	M6	M8	M10	M12
6	Distance ring	TA M T	K =	3,0	3,0	3,0	3,0

¹⁾ For specification - summary of washer for TA M see table 5

²⁾ For specification - summary of hexagon head bolt for TA M see table 4

Table 2: Materials

Part	Designation	Type of anchor	Materials	Treatment
1	Plastic cap ¹⁾	TA M / TA M S	Polyamid	
2	Cone-nut	TA M / TA M S / TA M T	Steel, EN 10 277	Zinc plated according to EN ISO 4042, min 5 μ m, additional functional coating
3	Expansion sleeve	TA M / TA M S / TA M T	Cold-rolled steel EN 10139	Zinc plated according to EN ISO 4042, min 5 μ m
4	Washer ²⁾	TA M S	Steel, min 140 HV	
8	Washer	TA M T		
5	Hexagon head bolt ³⁾	TA M S / TA M T	Steel, property class 8.8	
6	Distance ring	TA M T	Polyethylen	
7	Spacing sleeve	TA M T	Cold-rolled steel EN 10 139 / Steel EN10 277	Zinc plated according to EN ISO 4042, min 5 μ m

¹⁾ Optional

²⁾ For specification - summary of washer for TA M see table 5

³⁾ For specification - summary of hexagon head bolt for TA M see table 4

fischer Heavy-duty anchor TA M / TA M S / TA M T

Anchor dimensions and materials

Annex 3

of European
technical approval

ETA-04/0003

Table 3: Installation parameters for TA M / TA M S / TA M T

Anchor size		M6	M8	M10	M12
Nominal drill hole diameter	$d_0 = [\text{mm}]$	10	12	15	18
Cutting diameter of drill bit	$d_{\text{cut}} \leq [\text{mm}]$	10,45	12,50	15,50	18,50
Length of hexagon head bolt	$L_s \geq [\text{mm}]$	$t_{\text{fix}} + 50$	$t_{\text{fix}} + 55$	$t_{\text{fix}} + 70$	$t_{\text{fix}} + 85$
Depth of drill hole (TA M / TA M S)	$h_1 \geq [\text{mm}]$	$L_s - t_{\text{fix}} + 15$	$L_s - t_{\text{fix}} + 15$	$L_s - t_{\text{fix}} + 20$	$L_s - t_{\text{fix}} + 20$
Depth of drill hole (TA M T)	$h_1 \geq [\text{mm}]$	$L_s + 10$			
Diameter of clearance hole in the fixture (TA M / TA M S)	$d_f \leq [\text{mm}]$	7	9	12	14
Diameter of clearance hole in the fixture (TA M T)	$d_f \leq [\text{mm}]$	12	14	18	20
Required torque moment	$T_{\text{inst}} = [\text{Nm}]$	10	20	40	75
Thickness of fixture - min	$t_{\text{fix,min}} \geq [\text{mm}]$	1	1	1	1
Thickness of fixture - max	$t_{\text{fix,max}} \leq [\text{mm}]$	150	200	250	300

TA M / TA M S:

TA M T:

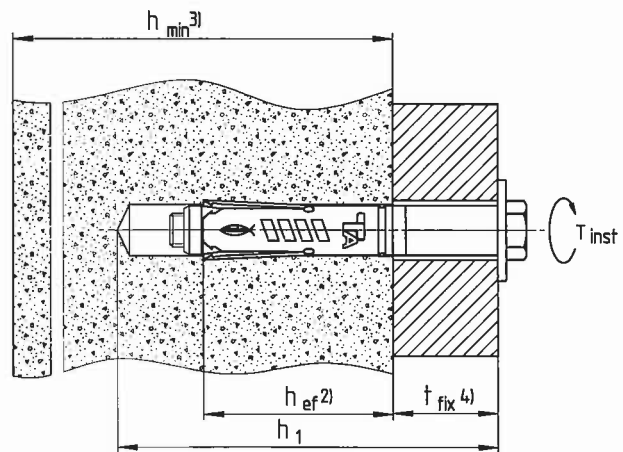
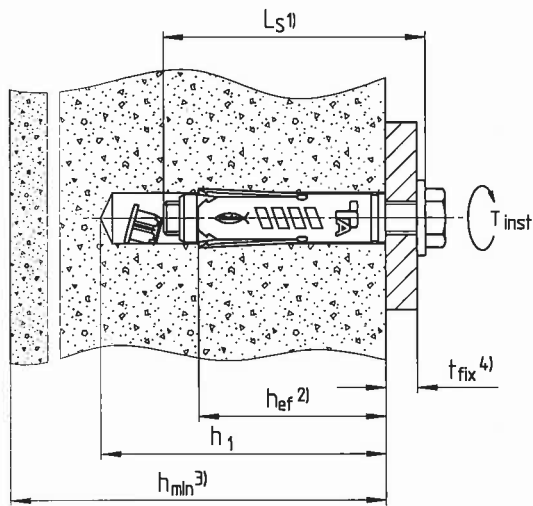

- 1) Length of hexagon head bolt L_s
- 2) Effective anchorage depth h_{ef}
- 3) Minimum thickness of concrete member h_{min}
- 4) Thickness of fixture t_{fix}

Table 4: Selection criteria for the hexagon head bolt (TA M)

Description	TA M6	TA M8	TA M10	TA M12
Length of hexagon head bolt L_S [mm]	$\geq t_{fix} + 50$	$\geq t_{fix} + 55$	$\geq t_{fix} + 70$	$\geq t_{fix} + 85$
Thread size	M6	M8	M10	M12
Standardisation	ISO 4014 / ISO 4017 or DIN 931 / DIN 933			
Material	Steel, property class 8.8			
Treatment	Zinc plated according to EN ISO 4042, min 5 μm			

Table 5: Selection criteria for the washer (TA M)

Description	TA M6	TA M8	TA M10	TA M12
Hole diameter D [mm]	min	6,0	8,0	10,0
	max	6,6	8,6	10,8
External diameter C [mm]	$\geq 11,0$	$\geq 15,0$	$\geq 19,0$	$\geq 23,0$
Thickness E [mm]	min	1,4	1,4	1,8
	max	3,0	3,0	4,0
Material	Steel, hardness class min 140 HV			
Treatment	Zinc plated according to EN ISO 4042, min 5 μm			

Table 6: Minimum thickness of concrete member, minimum spacings and minimum edge distances

Anchor size		M6	M8	M10	M12
Minimum thickness of concrete member	h_{min} [mm]	100	100	110	140
Minimum spacing	s_{min} [mm]	80	90	110	160
Minimum edge distance	c_{min} [mm]	50	60	70	120

Table 7: Characteristic values of resistance to tension loads of design method A

Anchor size				M6	M8	M10	M12
Steel failure							
Characteristic resistance	steel 8.8	$N_{Rk,s}$	[kN]	16,1	29,3	46,4	67,4
Partial safety factor	γ_{Ms}			1,5			
Pull-out failure							
Characteristic resistance in non-cracked concrete		$N_{Rk,p}$	C20/25	7,5	12	20	25
Increasing factors for $N_{Rk,p}$ in non-cracked concrete	ψ_c		C30/37	1,22			
			C40/50	1,41			
			C50/60	1,55			
Partial safety factor	γ_{Mp}			1,5 ¹⁾			
Concrete cone failure and splitting failure							
Effective anchorage depth	h_{ef}	[mm]		40	45	55	70
Spacing (concrete failure)	$s_{cr,N}$	[mm]		120	135	220	210
Edge distance (concrete failure)	$c_{cr,N}$	[mm]		60	68	110	105
Spacing (splitting)	$s_{cr,sp}$	[mm]		120	180	330	420
Edge distance (splitting)	$c_{cr,sp}$	[mm]		60	90	165	210
Partial safety factor	γ_{Mp}			1,5 ¹⁾			

¹⁾ the partial safety factor $\gamma_2 = 1,0$ is included

Table 8: Displacements due to tension loads

Anchor size				M6	M8	M10	M12
Tension load in non-cracked concrete	[kN]			3,0	4,8	7,9	9,9
Displacements	δ_{N0}	[mm]		0,7	0,7	1,2	1,2
	$\delta_{N\infty}$	[mm]		1,0	1,0	1,8	1,8

Table 9: Characteristic values of resistance to shear loads of design method A

Anchor size		M6	M8	M10	M12
Shear load without lever arm					
Characteristic resistance	steel 8.8 $V_{Rk,s}$ [kN]	5,8	11,7	19,2	29,8
Partial safety factor	γ_{Ms}	1,25			
Shear load with lever arm					
Characteristic bending moment	steel 8.8 $M_{Rk,s}^0$ [Nm]	12	30	60	105
Partial safety factor	γ_{Ms}	1,25			
Concrete pryout failure					
Factor in equation (5.6) of ETAG Annex C, 5.2.3.3	k	1,1	1,8	1,8	2,0
Partial safety factor	$\gamma_{Mc,p}$	1,5 ¹⁾			
Concrete edge failure					
Effective length of anchor in shear loading	l_f [mm]	40	45	55	70
Effective external diameter of anchor	d_{nom} [mm]	10	12	15	18
Partial safety factor	γ_{Mc}	1,5 ¹⁾			

¹⁾ the partial safety factor $\gamma_2 = 1,0$ is included

Table 10: Displacements due to shear loads

Anchor size		M6	M8	M10	M12
Shear load in non-cracked concrete	[kN]	3,3	6,7	11,0	17,0
Displacements	δ_{V0} [mm]	2,1	1,9	3,1	3,3
	$\delta_{V\infty}$ [mm]	3,1	2,8	4,6	4,9

Installation instruction for TA M / TA M S / TA M T

Pre-positioned installation TA M; TA M S

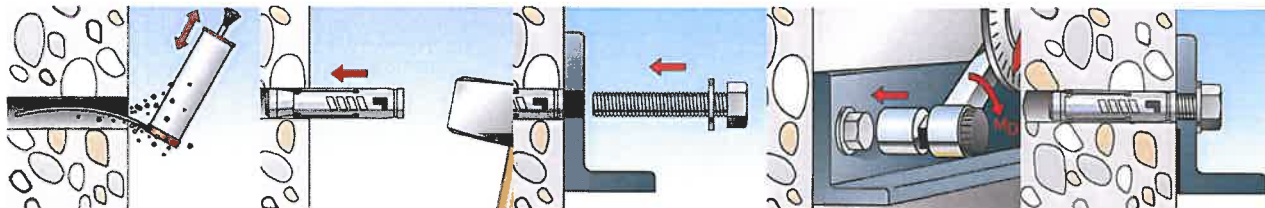

In-place installation TA M T

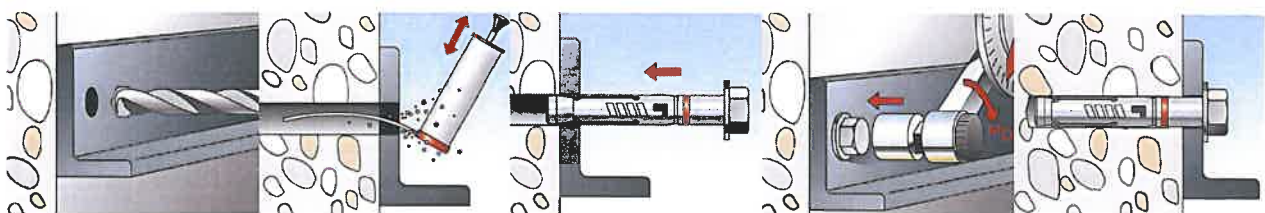

Doc: ETA-TAM-E

fischer Heavy-duty anchor TA M / TA M S / TA M T

Installation instruction

Annex 8
of European
technical approval
ETA-04/0003